

SCA Series

Compression Weighing Load Cells

**Capacities: 50,000 lb/22,680 kg,
100,000 lb/45,360 kg,
120,000 lb/54,430 kg**

- **Environmentally-sealed (IP68)**
- **Stainless steel construction**
- **35'/10m integral shielded cable**
- **2-year warranty**

These heavy-capacity compression load cells are ideal for multi-cell applications including truck scales, railroad track scales, and heavy-duty tank/hopper weighing systems.

The SCA load cells are fabricated from stainless steel to provide the ultimate in protection when caustic, corrosive or wet environments are encountered.

Load cells are environmentally-sealed for absolute water protection. Each load cell is furnished with stainless steel load buttons on each end, and an integral multi-conductor cable secured by a strain relief seal.

MECHANICAL DATA

Rated Capacity, (R.C.) E_{max}	50,000 lb / 22,680 kg, 100,000 lb / 45,360 kg, 120,000 lb / 54,430 kg
Minimum Dead Load	500 lb / 226 kg, 1,000 lb / 454 kg, 1,200 lb / 544 kg
Safe Load Limit	150% R.C.
Ultimate Load	300% R.C.
Deflection at R.C.	0.01 in / 0.33 mm
Net Weight	50K-SCA: 13 lb / 5.8 kg 100K-SCA: 10 lb / 4.8 kg 120K-SCA: 11 lb / 5 kg

ELECTRICAL DATA

Rated Output	2mV/V
Excitation Voltage, Minimum	10 VDC
Excitation Voltage, Maximum	15 VDC
Cable Length	35 ft / 10 m
Terminal Resistance	
Excitation	1,150 ± 60 ohms
Signal	1,050 ± 15 ohms
Zero Load Output	>2% R.C.
Insulation Resistance	>5,000 megohms at 50 VDC

CERTIFICATE DATA

ISSUING BODY	NTEP	OIML
Certificate Number	89-042A4	R60/1991-DK-97.04 rev 1
Accuracy Class	III L	C3
Maximum Number of Load Cell Intervals, n_{max}	10,000	3,000
Single/Multiple	M	
Humidity Symbol		CH
Minimum Load Cell Verification Interval V_{min}	1.5 lb/0.68 kg, 3 lb/1.36 kg, 3.6 lb/1.63 kg	1 lb/0.45 kg, 2 lb/0.9 kg, 2.4 lb/1.09 kg

ENVIRONMENTAL DATA

Temperature Compensation Range	-10 to +40°C
Operating Temperature Range	-29 to +93°C
Construction & Protection Code	CP-67 HU, IP68
Barometric Pressure Effect on Zero Load Output	<1 v (min)/1kPa

LOAD CELL S

SCA Series

Compression Weighing Load Cells

Model 50K-SCA

Model 100K-SCA

Model 120K-SCA

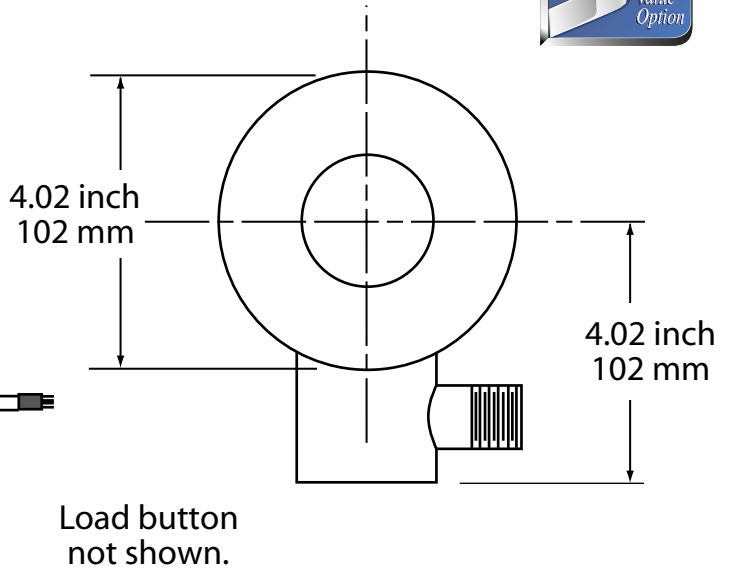
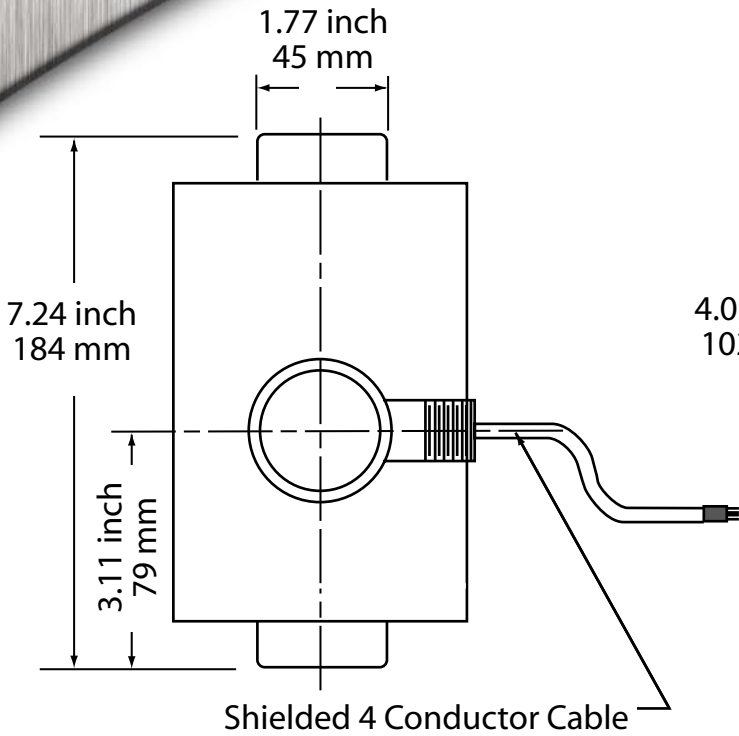

ELECTRICAL INFORMATION

- Green + excitation
- Black - excitation
- Shield - Yellow
- White - signal
- Red + signal

State-of-the-Art Load Cell Manufacturing Facility
ISO 9001 Quality Environment



CERTIFICATIONS

The Model SCA Load Cell meets or exceeds Class III, 10,000 division accuracy requirements in accordance with NIST Handbook 44. A Certificate of Conformance (Number 89-042A4) has been issued under the National Type Evaluation Program (NTEP) of the National Conference on Weights and Measures.



R60/1991-DK-97.04 rev 1

VCAP CERTIFIED

Cardinal Scale has been found to fully comply with the Verified Conformity Assessment Program (VCAP) administered by the National Type Evaluation Program (NTEP) of the National Conference on Weights and Measures (NCWM).

Cardinal Scale reserves the right to improve, enhance or modify features and specifications without prior notice. All registered trademarks are the property of their respective owners.

Cardinal
Cardinal Scale Manufacturing Co.
203 E. Daugerty, Webb City, MO 64870 USA
Ph: 417-673-4631 or 800-441-4237 • Fax: 417-673-5001
www.CardinalScale.com

SOLD BY:

